

MAVENCA 70

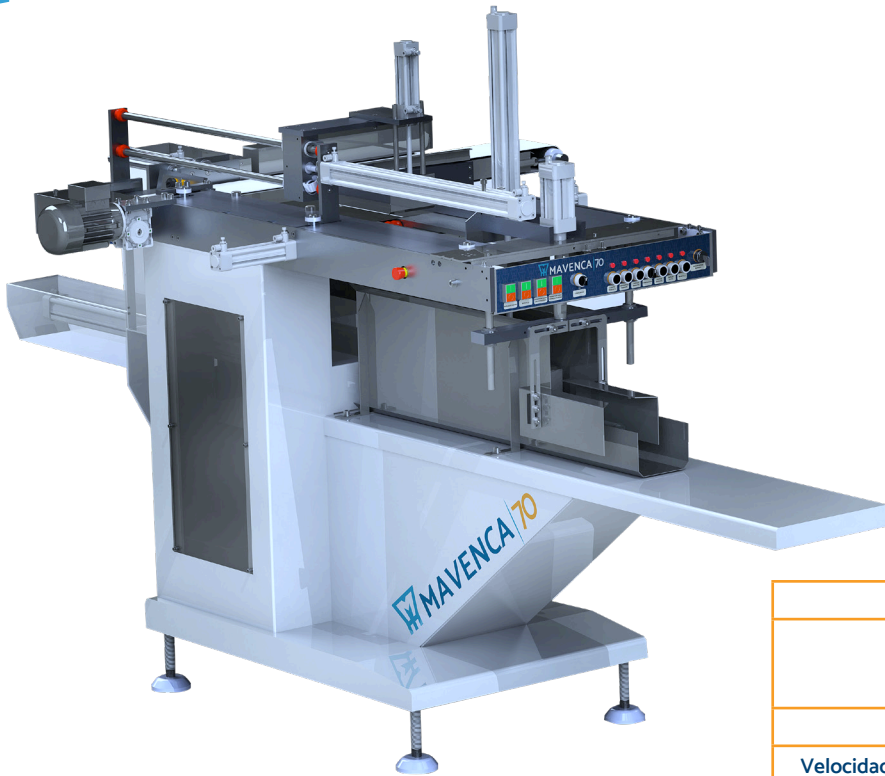

La enfardadora **MAVENCA 70** es una agrupadora semiautomática de paquetes desde 200 gr hasta 2 kg en formato de 20 o 24 paquetes según la necesidad del cliente, en bultos de material plástico, papel o cajas de cartón.

ESPECIFICACIONES TÉCNICAS

Tipo de Equipo	Enfardadora Semiautomática.
Producto	Cereales, Azúcares. Leguminosas, productos libremente fluyentes.
Peso Paquete	200 gr - 2 kg
Velocidad Máxima de Empaquetado	2 fardos/min.
Marca Precio	No.
Pantalla Táctil	No.
Tablero de Control	Si.
Requerimiento Eléctrico	220 V - Trifásico.
Consumo Eléctrico	3 - 14 A
Red de Aire Comprimido	6 - 8 bar // 87 - 116 psi
Consumo de Aire	2696 lt/min.
Peso Neto (Aproximado)	350 kg
Dimensiones	1680 x 1781 x 3174 mm

TIPOS DE FARDOS

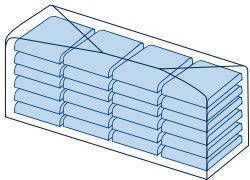

Bultos de 6 Unid. x 4 Unid. = 24 Unid.

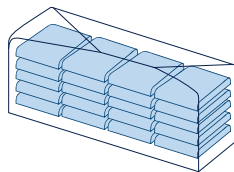

Bultos de 5 Unid. x 4 Unid. = 20 Unid.

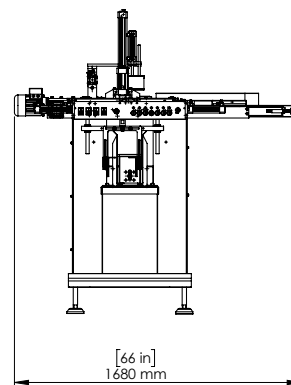
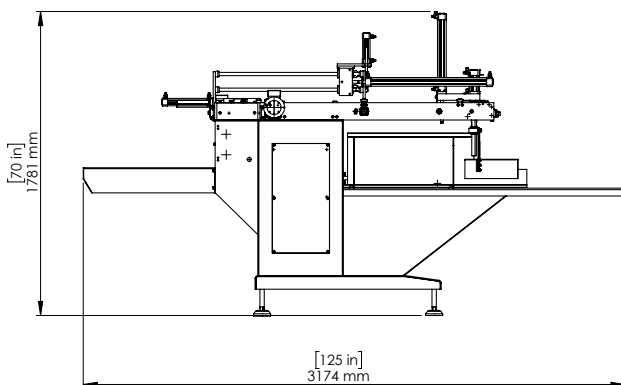

Oficina y Planta Principal: Calle 4 esquina Carrera 2 galpón N° 2 Zona Industrial III.
Barquisimeto, Estado Lara - Venezuela.
Teléfonos: (0251)-269.24.32; (0251)-269.20.97
Web: www.mavenca.com
E-mail: ventas@mavenca.com

MAVENCA 70

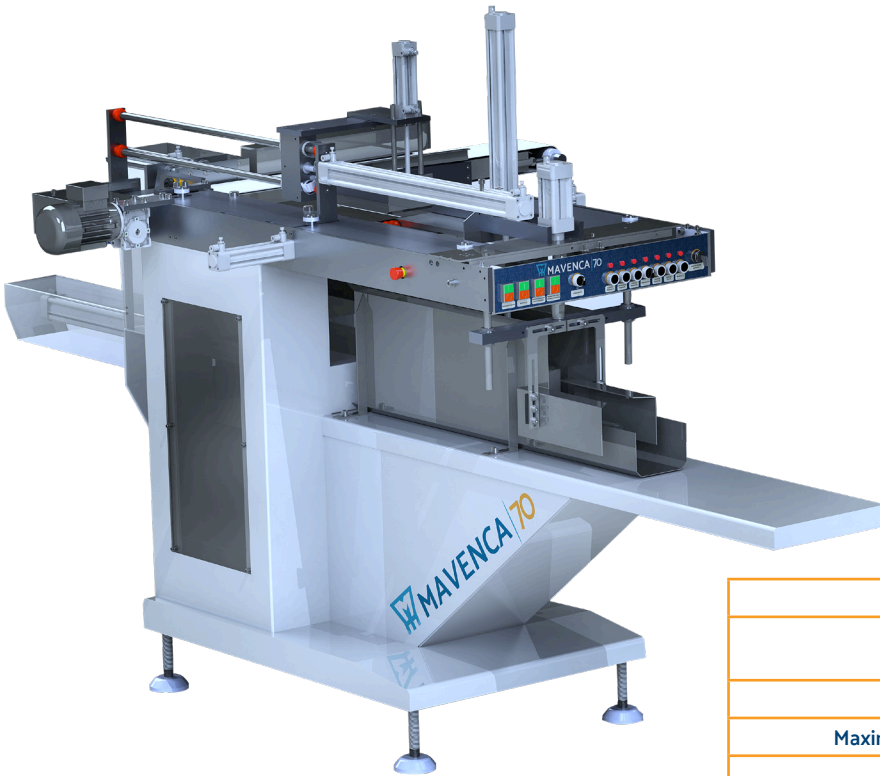

The baler **MAVENCA 70** is a semiautomatic packet grouping from 200 grams to 2 kilos in 20 or 24 packet format according to the customer's needs in plastic, paper, or cardboard boxes.

TECHNICAL SPECIFICATIONS

Machine Type	Semi-automatic Baler Machine.
Product	Cereals, sugars, Legumes, freely flowing products..
Package Weight	7 - 70 ½ oz
Maximum Packaging Speed	2 bales/min
Machine Price	No.
Touch Screen	No.
Control panel	Yes.
Electrical Requirement	220 V - three phase connection.
Power consumption	3 - 14 A
Compressed Air Network	6 - 8 bar // 87 - 116 psi
Air consumption	712 gal/min
Net Weight (Approximate)	772 lb
Dimensions	66 x 70 x 125 in

BALES TYPES

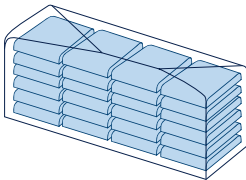

Bales of 6 Units. x 4 Units. = 24 Units.

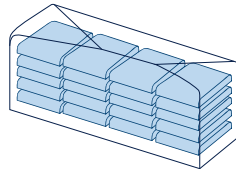

Bales of 5Units. x 4 Units. = 20 Units.

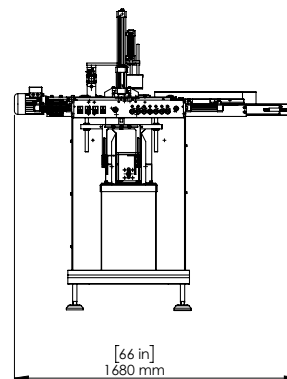
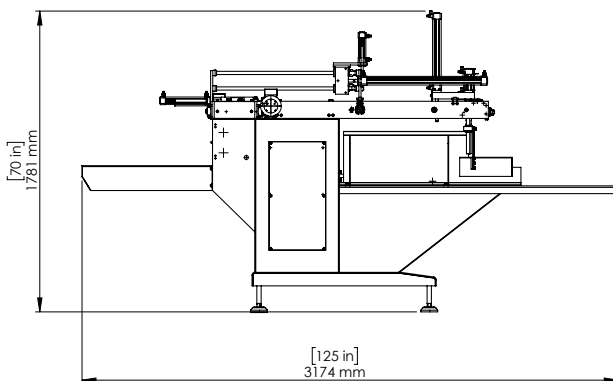

Office and Main plant: street 4 corner street 2 industrial plant No. 2 Industrial Zone III.
Barquisimeto, Lara State - Venezuela.
phone number: (+58) (251)-269.24.32; (251)-269.20.97
Web: www.mavenca.com
E-mail: ventas@mavenca.com