

MAVENCA | 2000T



La empaquetadora **Mavenca 2000T (Tornillo)**, es un equipo de alimentación a través de tornillo de acero inoxidable y servo motor. Posee un tablero frontal de fácil instalación, operación y sencillo mantenimiento. Está en capacidad de empaclar entre 16 y 21 toneladas métricas diarias.*

*Flujo másico dependerá de características del producto, empaque y tiempo de funcionamiento.

ESPECIFICACIONES TÉCNICAS

Tipo de Equipo	Empaquetadora Automática.
Producto	Leche en Polvo, Café en Polvo, Harinas, Chocolate en Polvo, entre otros.
Peso Paquete	100 gr - 1 kg
Velocidad Máxima de Empaquetado	50 paquetes/min.
Marca Precio	Adaptable.
Pantalla Táctil	Si.
Tablero de Control	Si.
Requerimiento Eléctrico	220 V - Trifásico.
Consumo Eléctrico	3 - 14 A
Red de Aire Comprimido	6 - 8 bar // 87 - 116 psi
Consumo de Aire	309 lt/min.
Peso Neto (Aproximado)	600 kg
Dimensiones	1261 x 2858 x 1589 mm

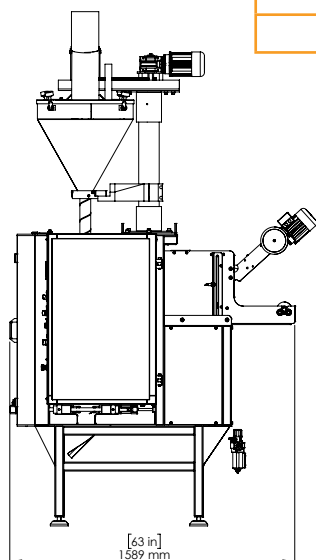
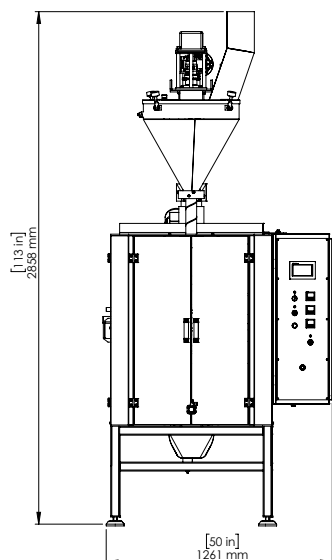

TIPOS DE EMPAQUES

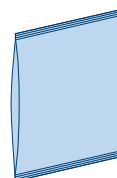

Almohada Estriada

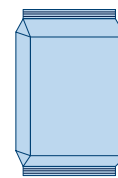

Almohada con fuelle estriada



Oficina y Planta Principal: Calle 4 esquina Carrera 2 galpón N° 2 Zona Industrial III.
Barquisimeto, Estado Lara - Venezuela.
Teléfonos: (0251)-269.24.32; (0251)-269.20.97
Web: www.mavenca.com
E-mail: ventas@mavenca.com

MAVENCA | 2000T



The Mavencia 2000T (Screw) packing machine is a feeding device through stainless steel screw and servo motor. It has a front panel for easy installation and operation, and simple maintenance. It is capable of packing between 18 – 23 sh. t. daily*.

*Mass flow depends on product characteristics, packaging and operating time.

TECHNICAL SPECIFICATIONS

Machine Type	Automatic packing machine.
Product	Milk Powder, Coffee Powder, Flours, Chocolate Powder, others.
Package Weight	3 ½ oz - 2.20 lb
Maximum Packaging Speed	50 packages /min
Machine Price	Adaptable.
Touch Screen	Yes.
Control panel	Yes.
Electrical Requirement	220 V - three phase connection.
Power consumption	3 - 14 A
Compressed Air Network	6 - 8 bar // 87 - 116 psi
Air consumption	82 gal/min
Net Weight (Approximate)	1323 lb
Dimensions	50 x 113 x 63 in

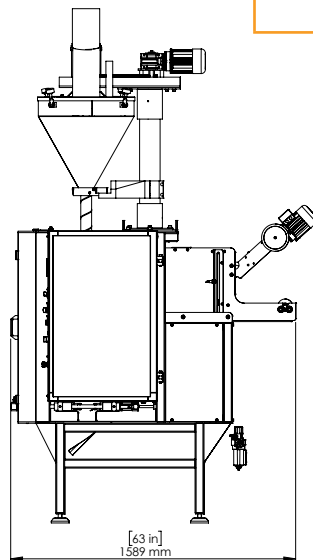
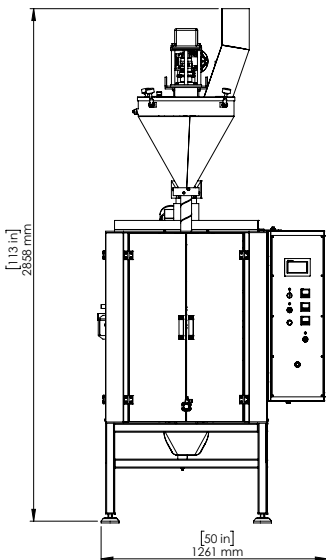

PACKAGING TYPES

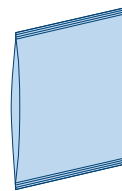

Pillow bag

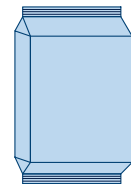

Corrugated bag



Office and Main plant: street 4 corner street 2 industrial plant No. 2 Industrial Zone III.
Barquisimeto, Lara State - Venezuela.
phone number: (+58) (251)-269.24.32; (251)-269.20.97
Web: www.mavencia.com
E-mail: ventas@mavencia.com