

MAVENCA | 120



La enfardadora **MAVENCA 120** es una agrupadora automática de paquetes desde 500 gr hasta 5 kg en formatos de 5, 10, 12, o 24 paquetes según la necesidad del cliente.

Esta máquina cuenta con un sincronizador de paquetes que la convierte en un equipo de gran utilidad para procesos que trabajan con dos (2) empaquetadoras.

ESPECIFICACIONES TÉCNICAS

Tipo de Equipo	Enfardadora Automática.
Producto	Cereales, Azúcares. Leguminosas, Avena en Hojuelas, productos libremente fluyentes.
Peso Paquete	500 gr - 5 kg
Velocidad Máxima de Empaquetado	3 fardos/min.
Marca Precio	No.
Pantalla Táctil	Si.
Tablero de Control	Si.
Requerimiento Eléctrico	220 V - Trifásico.
Consumo Eléctrico	3 - 14 A
Red de Aire Comprimido	6 - 8 bar // 87 - 116 psi
Consumo de Aire	1058 lt/min.
Peso Neto (Aproximado)	500 kg
Dimensiones	2000 x 2300 x 1546 mm

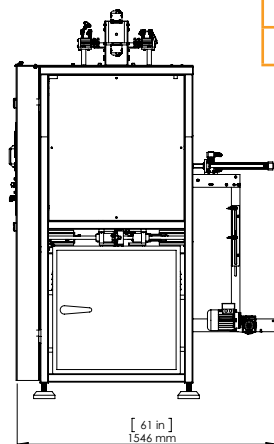
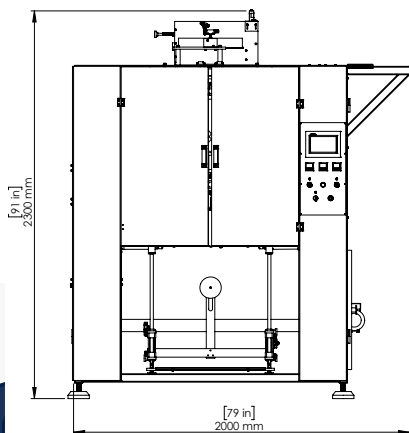

TIPOS DE FARDOS

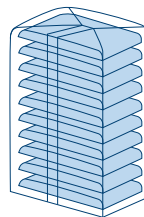

Fardos de 10 Unid. x 1 Unid. = 10 Unid.
Fardos de 12 Unid. x 1 Unid. = 12 Unid.

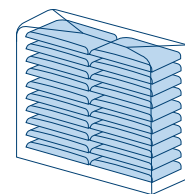

Fardos de 10 Unid. x 2 Unid. = 20 Unid.
Fardos de 12 Unid. x 2 Unid. = 24 Unid.



Oficina y Planta Principal: Calle 4 esquina Carrera 2 galpón N° 2 Zona Industrial III.
Barquisimeto, Estado Lara - Venezuela.
Teléfonos: (0251)-269.24.32; (0251)-269.20.97
Web: www.mavenca.com
E-mail: ventas@mavenca.com

MAVENCA | 120



The **MAVENCA 120** baler is an automatic packet grouper from 1.1 lb up to 11 lb in formats of 5, 10, 12, or 24 packages according to customer needs. This machine has a package synchronizer that makes it a very useful equipment for processes that work with two (2) packaging machines.

TECHNICAL SPECIFICATIONS

Machine Type	Automatic Baler Machine
Product	Cereals, Sugar, Legumes, Flaked oatmeal, Freely Flowing Products.
Package Weight	1.1 - 11 lb
Maximum Packaging Speed	3 bales/min
Machine Price	No.
Touch Screen	Yes.
Control panel	Yes.
Electrical Requirement	220 V - three phase connection.
Power consumption	3 - 14 A
Compressed Air Network	6 - 8 bar // 87 - 116 psi
Air consumption	280 gal/min
Net Weight (Approximate)	1102 lb
Dimensions	79 x 91 x 61 in

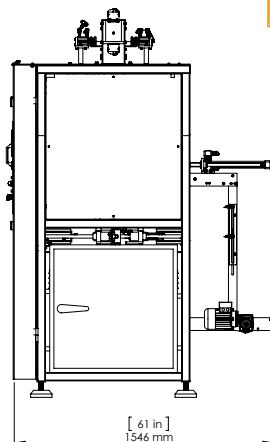
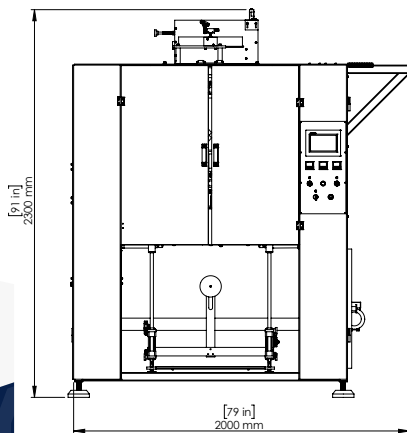

BALES TYPES

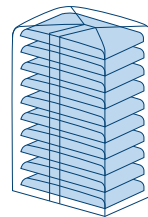

Bales of 10 Units. x 1 Unit. = 10 Units.
Bales of 12 Units. x 1 Unit. = 12 Units.

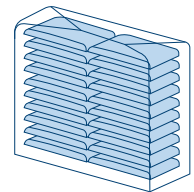

Bales of 10 Units. x 2 Unit. = 20 Units.
Bales of 12 Units. x 2 Unit. = 24 Units.



Oficina y Planta Principal: Calle 4 esquina Carrera 2 galpón N° 2 Zona Industrial III.
Barquisimeto, Estado Lara - Venezuela.
Teléfonos: (0251)-269.24.32; (0251)-269.20.97
Web: www.mavenca.com
E-mail: ventas@mavenca.com